

AIR TRAFFIC & DEFENSE

AERONAUTICAL MESSAGE HANDLING SYSTEM

Avitech - Leading Technology for Efficient and Reliable
AMHS Solutions

www.avitech.aero

AMHS



AVITECH - YOUR TRUSTED GUIDE FROM AFTN TO AMHS

Our AFTN-to-SWIM and AMHS-to-SWIM Gateway provides optimum solutions for a safe and reliable exchange of messages – serving the major players in the global aeronautical network.

Our Competence

In a complex aeronautical environment we devote ourselves to support you with the best available message formats, protocols and interfaces.

We follow ICAO SARPs as well as regional standards and recommendations while implementing customised functions according to your specific requirements.

Serving your Needs

We supply our long-term experience in aeronautical message handling to provide you with state-of-the-art solutions tailored perfectly to your individual specifications. Our national and international civil and military COM Centers and messaging clients are designed to ensure interoperability between users in different environments swiftly and easily. Our gateways provide a safe and reliable automatic transition of messages between various formats and protocols. The latest Avitech gateway is bridging the gap between AFTN/AMHS and SWIM technology.

Avitech MHS Technology

Avitech is known as a groundbreaking pioneer in aeronautical message handling since the 1970s. Over four decades we have been continuously researching and growing and we still keep setting trends. We take pride in our many achievements, always providing our customers with up-to-date, high quality solutions.

Having started with AFTN, growing with CIDIN and AMHS, we today combine these applications to provide you with the best available intelligently integrated systems. Over the years we earned the trust of many Air Navigation Service Providers, Airlines and Civil/Military Aviation Authorities implementing our MHS solutions.

Our commitment and enthusiasm is reflected in our customers' satisfaction – exactly what we are striving for in every project we are involved in.

Two Way AFTN/AMHS - SWIM Messaging

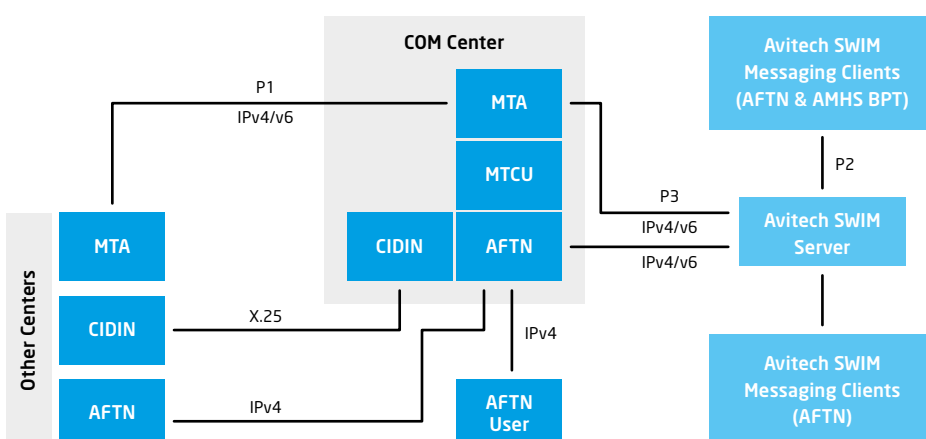

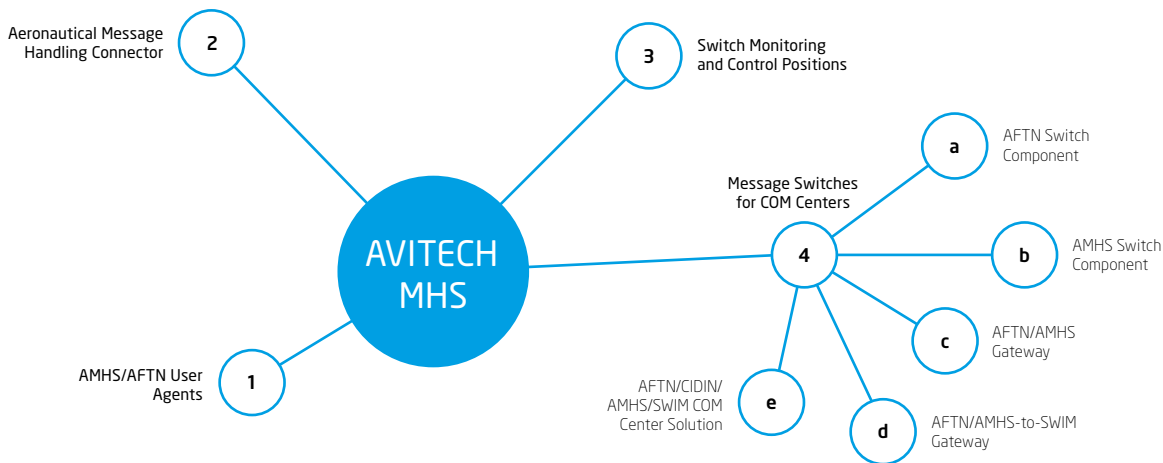

MHS Product Range

Avitech guides your processes safely and supports you in establishing your best MHS solution. All our products and solutions can be in detail adapted to your requirements, resulting in exactly the Message Handling System you need. Take a look at our MHS modules:

1 AMHS/AFTN User Agents

Avitech User Agents have been developed to combine the convenience of a highly sophisticated ATS terminal application with the message handling capabilities of AMHS and/or AFTN. Our product range includes both AMHS User Agents and AFTN User Agents. An easy migration between the two of them is achieved by a common look and feel as well as an automatic conversion of addresses between AFTN and AMHS. Our solutions include the reception and transmission of messages, forms to edit various message types, parsing of received messages for proper display, storage and use of message templates plus powerful search functions with various criteria. The application can be installed as a stand-alone client or as web start client to support roaming users. Enables the System Agent Directory to take part in EDS (European Directory Service).

2 Aeronautical Message Handling Connector

The MHS Connector is designed to connect legacy applications to AFTN or AMHS switches by use of a simple internal XML file interface. Automatic conversion between AFTN and AMHS addresses allows applications to use AFTN addresses. There is no need to implement AMHS elements into the legacy application. The MHS Connector decouples the application and communication systems.

3 Switch Monitoring and Control Positions

Avitech switches are equipped with a state-of-the-art user interface. They allow administrators and operators to access, monitor and control the application, to configure it easily according to operational needs and to import look-up tables. Avitech switches facilitate powerful message retrieval and repetition functions, correction of faulty messages as well as system statistics.

4 Message Switches for COM Centers

Due to their modular design Avitech solutions for COM Centers are available in the following variants: AFTN switches, AMHS switches, AFTN/CIDIN switches, AFTN/CIDIN/AMHS switches, AFTN/AMHS gateways, two way SWIM gateways for AFTN-SWIM and AMHS-SWIM.

- a The **AFTN Switch Component** within our switches is fully compliant with Annex 10 Vol. II. It is available with various network interfaces from classical serial lines or TCP/IP-to-SMS and other interfaces according to your specification.
- b The **AMHS Switch Component** is based on the ITU-T X.400 (ISO/IEC 10021-1) Message Handling standard and fully compliant with ICAO Doc 9880, ICAO EUR Doc 020 – EUR AMHS Manual, EU SPEC 136 on AMHS. It provides support for the Basic and Extended ATS Message Handling Service as well as for File Transfer Body Part (FTBP) to exchange binary data.
- c Our **AFTN/AMHS Gateway** is developed to support interoperability by connecting AMHS with existing AFTN switches. It is fully compliant with ICAO Doc 9880.
- d Our **AFTN/AMHS-to-SWIM Gateway** establishes a bridge between AFTN/AMHS messages and SWIM messages provided that user systems or clients implement an Avitech SWIM client or uses the P3 AMHS protocol. Our solution is set to implement IwXXM profile according to EUR AMHS Manual Appx. H.
- e By combining all Avitech MHS switch components to a full **AFTN/CIDIN/AMHS/SWIM COM Center Solution**, you save your investment for communications systems as your solution covers already SWIM and SWIM Messaging.

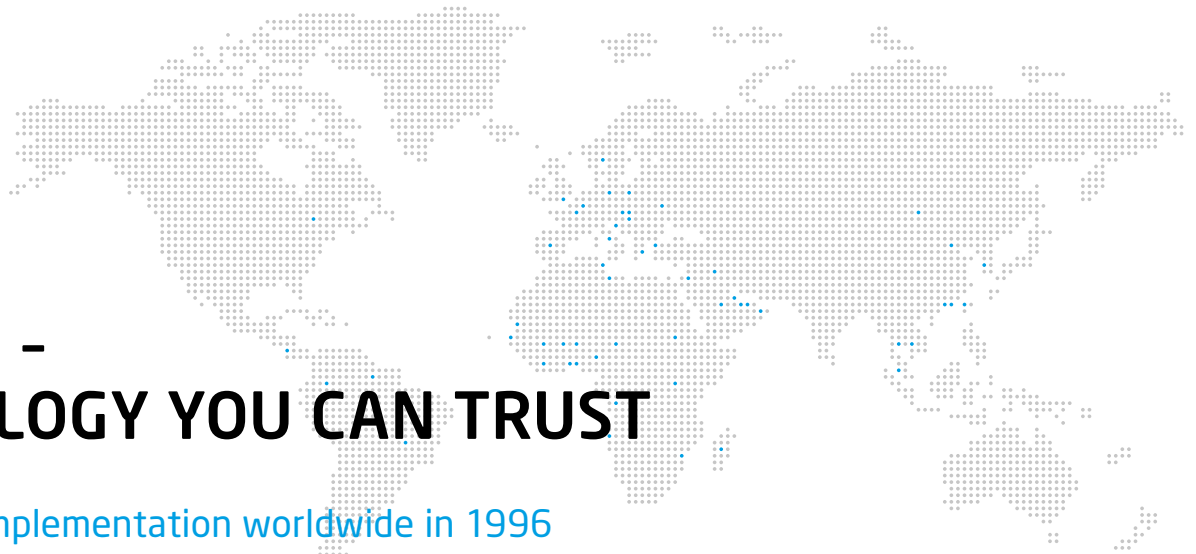

AVITECH - TECHNOLOGY YOU CAN TRUST

- First AMHS Implementation worldwide in 1996
- Nine operational AMHS COM Centers implemented for ASECNA - Avitech exclusively providing AMHS links within the ICAO AFI Region
- ATS Messaging Management Center Connection
- AFTN / AMHS-to-SWIM Gateway
- Connector to any Aeronautical Fixed Service

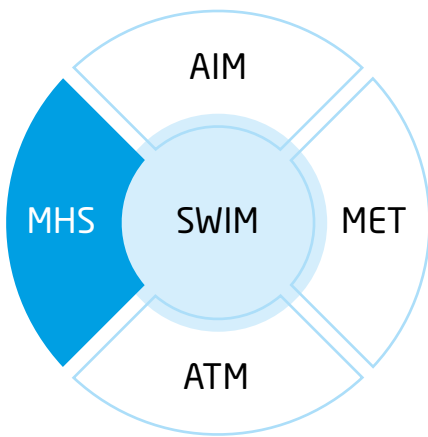

Experience & Know-how

Our MHS products for the aviation industry include solutions for AFTN, CIDIN, AMHS and SWIM Messaging. Besides our purely civil solutions for Air Navigation Service Providers and Communication Service Providers, one of our main focuses is on the civil and military interoperability interfaces for Aeronautical Data and Messages.

For more than 40 years Avitech has served the aviation industry as one of the leading international developers of aeronautical IT systems worldwide. Today Avitech supplies more than 45 customers in 55 countries on six continents with state-of-the-art aeronautical information technology.

Please ask for our complete product range or visit our website www.avitech.aero

Avitech & Indra

Avitech represents the Center of Excellence within the Indra Group for AIM, MHS, SWIM and MET, complementing the Indra ATM offering worldwide. The Indra Group's global business model is based on high-end innovation and technology, currently supporting 4000 air traffic control installations in over 160 countries.

The group is all set for ICAO Aviation System Block Upgrades (ASBUs): Compliance with Block 0 & Block 1 and paving the way to Blocks 2 & 3.

 **ASBU-Compliance**



2013 — 2019 — 2024



www.avitech.aero